

DS9120 Socket Boards for Evaluating 1-Wire Devices

General Description

The DS9120 family of socket boards are RJ11-to-socket boards that provide the hardware connectivity necessary to evaluate and operate 1-Wire[®] products in an easy-to-use PC environment. Additionally, the socket boards can be readily used with the DS9481R USB-to-1-Wire adapter to create a 1-Wire PC programmer for 1-Wire EEPROM and one-time programmable (OTP)/EPROM devices.

Socket Board Contents List (Included with Each Order)

QTY	DESCRIPTION
1	1-Wire socket board Maxim DS9120*
1	RJ11 cable assembly I.O. Interconnect
1	Instruction sheet

*See the [Ordering Information](#) table for package type/part number options.

Support Resources

- 1) DS9120 Family of 1-Wire Socket Boards:
www.maxim-ic.com/DS9120
- 2) DS9481R USB-to-1-Wire/iButton Adapter:
www.maxim-ic.com/DS9481R
- 3) 1-Wire Technical Support:
<https://support.maxim-ic.com/1-Wire>

[Ordering Information](#) appears at end of data sheet.

Features

- ◆ Fully Compliant with DS9481R USB-to-1-Wire Adapter
- ◆ Convenient On-Board Test Points
- ◆ Jumper Disconnect/Connect Functionality
- ◆ Meets RJ11 1-Wire Interface Standard
- ◆ Include Connections for Various OTP EPROM Programming

Socket Board (Shown with DS9120P)

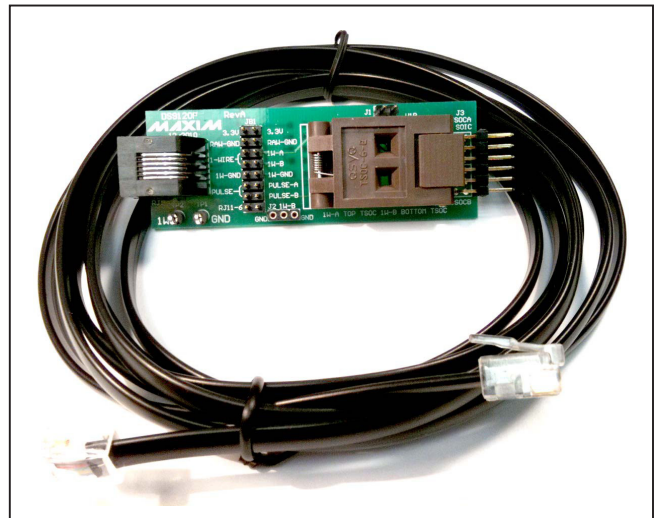

1-Wire and iButton are registered trademarks of Maxim Integrated Products, Inc.

DS9120 Socket Boards for Evaluating 1-Wire Devices

Selector Guide

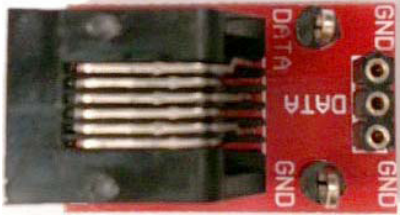
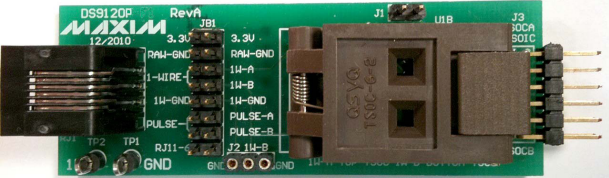
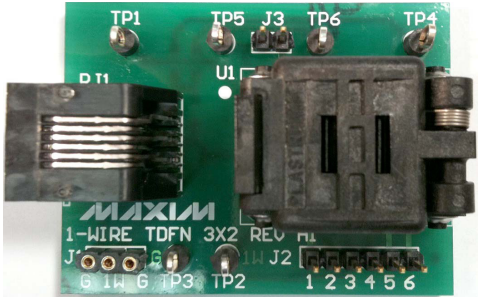
MAXIM ORDERING PART NUMBER	SOCKET MANUFACTURER/PART NUMBER	DESCRIPTION
DS9120+	Mill-Max 801-93-036-10-012000	 <p>TO-92 Socket with RJ11 Connector</p>
DS9120P+	QSYQ TSOC-6-2	 <p>Dual TSOC and TO-92 Sockets with RJ11 Connector</p>
DS9120Q+	Plastronics 06QN10T23030-H	 <p>TDFN and TO-92 Sockets with RJ11 Connector</p>

DS9120 Socket Boards for Evaluating 1-Wire Devices

Detailed Description of Hardware

1-Wire Socket Boards

The DS9120 family of 1-Wire socket boards are 1-Wire accessories that support 1-Wire EEPROM, EPROM, and ROM devices for different packages. See the [Ordering Information](#) table to determine which socket board is available for each package type. All socket boards include the socket and RJ11 cable assembly (see the [Socket Board Contents List \(Included with Each Order\)](#) table for the complete list).

DS9120P Jumper Settings

The DS9120P socket board for the TSOC package requires jumpers for communication. The only reason for these jumpers is for debugging, or to break out the RJ11 signals. Set the jumpers as shown in [Figure 1](#) for parasitically powered devices, and set the jumpers as shown in [Figure 2](#) for nonparasitically powered devices.

Additionally, note that when evaluating a DS2413P device, jumpers J1 and J4 are to be populated. For all other 1-Wire slave devices, do not populate J1 or J4 with a jumper.

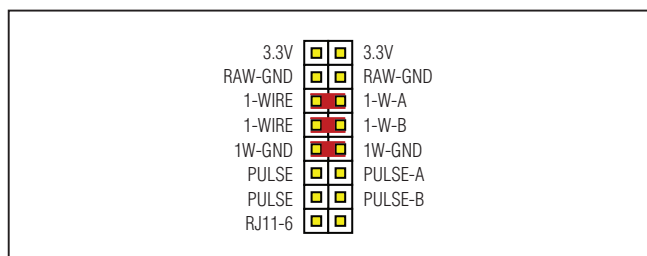

Figure 1. Jumper Settings for Parasitic Power

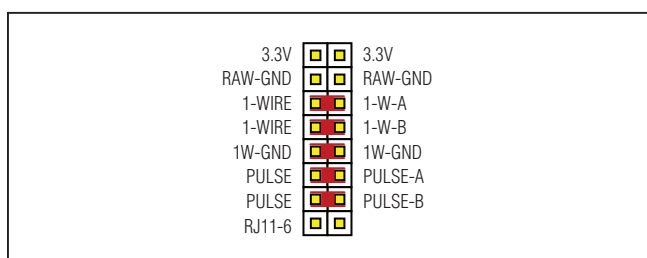

Figure 2. Jumper Settings for VCC Power and OTP Programming for DS28E10

DS9120Q Jumper Settings

The DS9120Q socket board should only have J3 jumper populated when evaluating a DS2413Q device. For all other 1-Wire slave devices, do not populate J3 with a jumper.

RJ11 Pinout

[Table 1](#) shows the RJ11 pinout at RJ11 mounted on each DS9120 socket board. This also matches the RJ11 pinout for the DS9481R. RJ11 pin 1 can supply 3.3V and can be used for auxiliary board power. GND is ground of the 3.3V supply. The signal OW (DATA) stands for the 1-Wire data bus. The ground return for OW (DATA) is the signal OWGND. The PULSE signal is to be used as the VCC power supply for OTP EPROM memory devices. The PULSE signal is typically 3.3V, but can also provide the needed programming pulse for 7V OTP EPROM memory devices. The GP signal is reserved for future general-purpose use and is functionally not used by the DS9481R.

Table 1. 1-Wire RJ11 Pinout

CONNECTOR PIN	SIGNAL NAME	PIN ROUTED ON PCB
1	3.3V	DS9120P, DS9120Q
2	GND	DS9120P
3	OW (DATA)	DS9120P, DS9120Q, DS9120
4	OWGND	DS9120P, DS9120Q, DS9120
5	PULSE	DS9120P
6	GP	DS9120P

DS9120 Socket Boards for Evaluating 1-Wire Devices

DS9120 Family of Socket Board Schematics and Layout

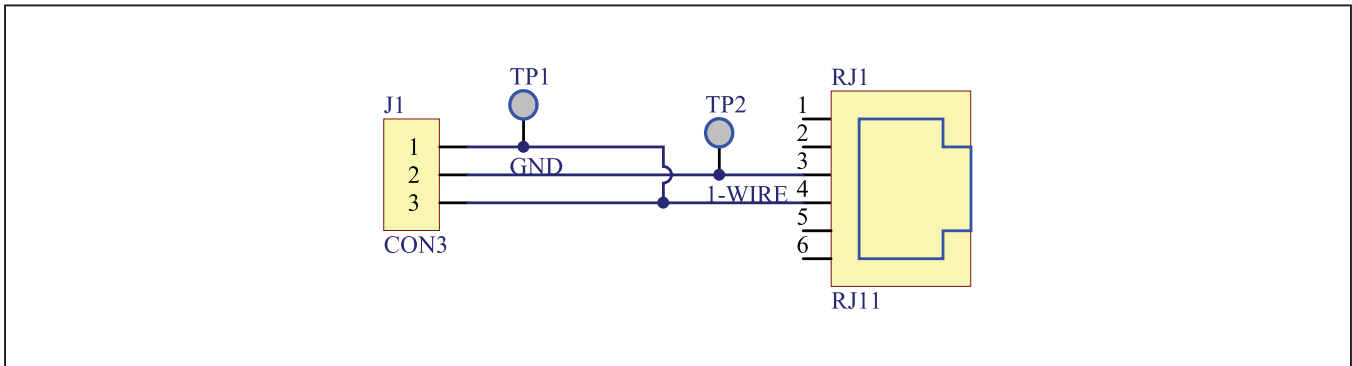

Figure 3. DS9120+ Socket Board Schematic

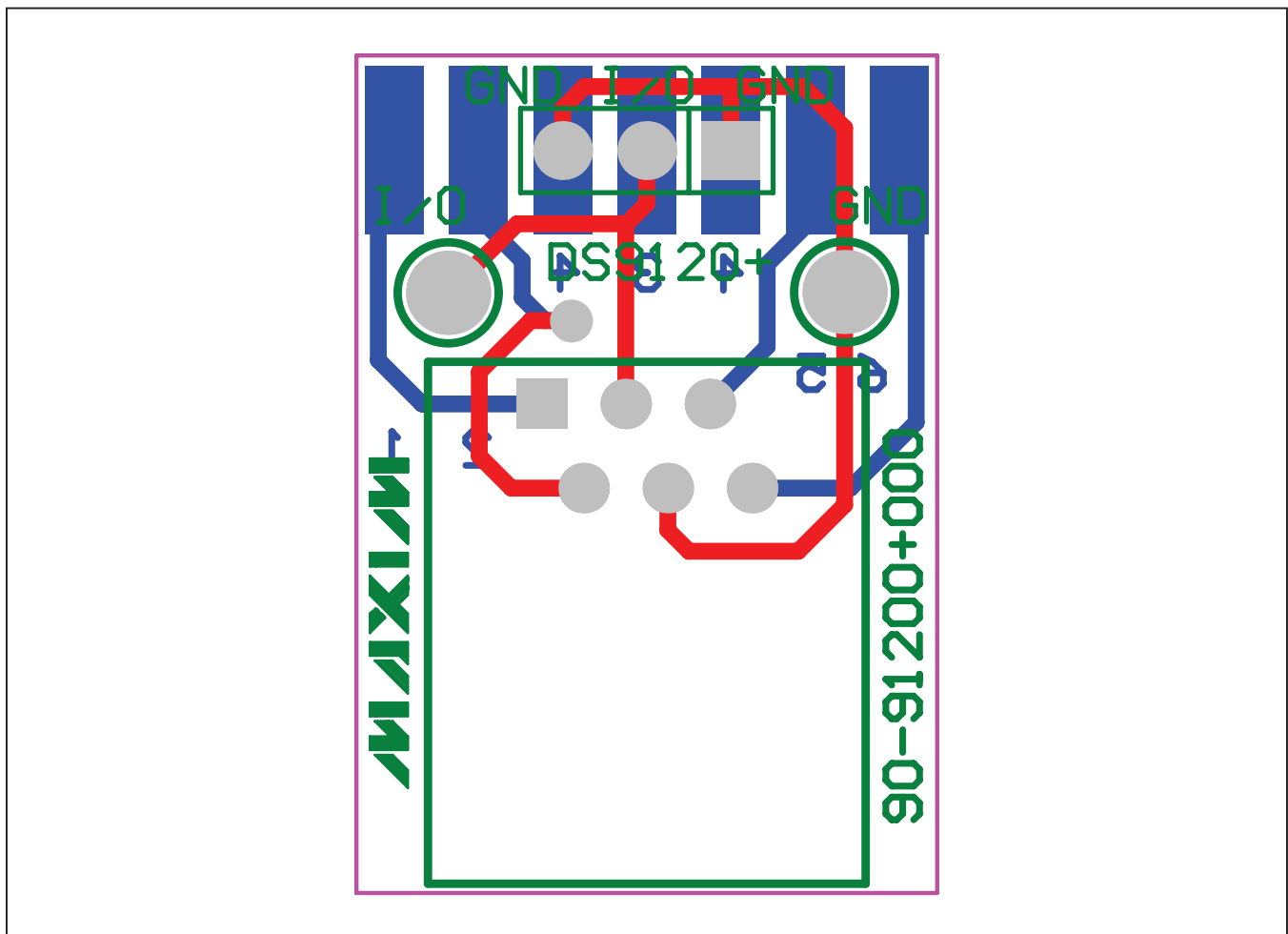

Figure 4. DS9120+ Socket Board Composite Layout

DS9120 Socket Boards for Evaluating 1-Wire Devices

DS9120 Family of Socket Board Schematics and Layout (continued)

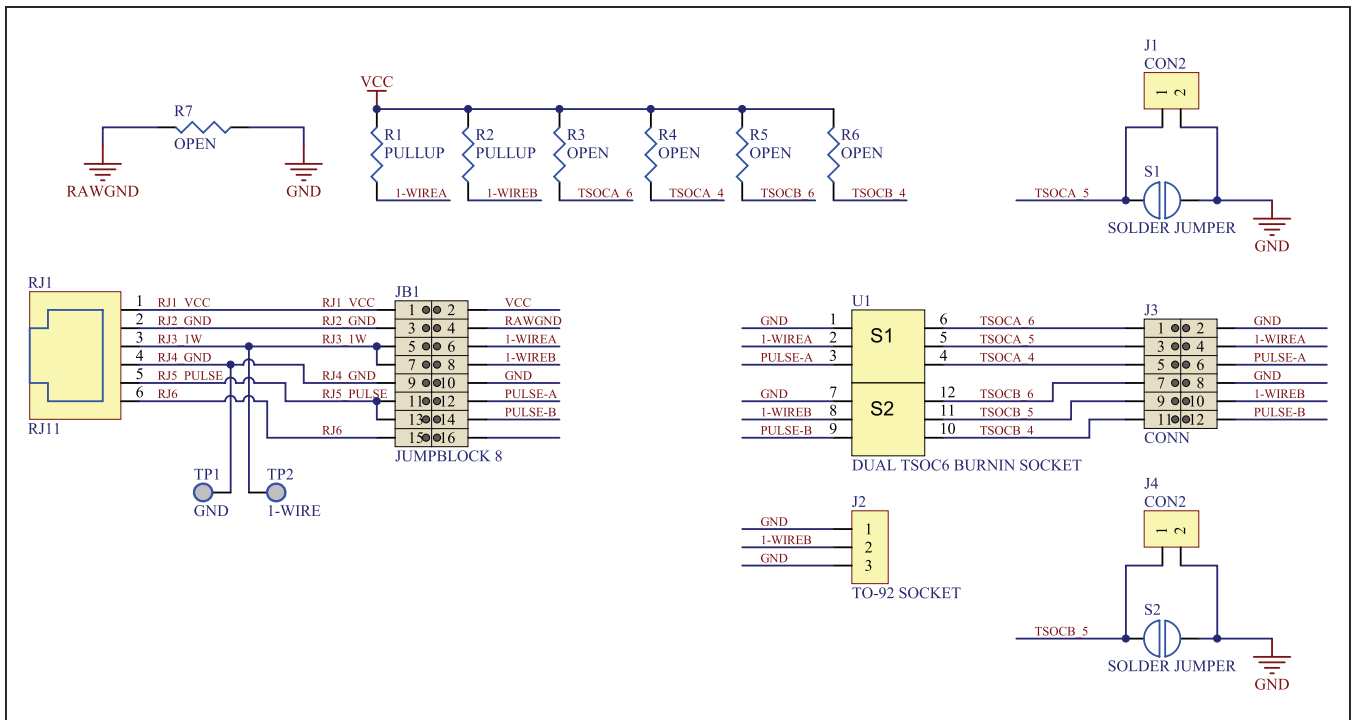

Figure 5. DS9120P+ Socket Board Schematic

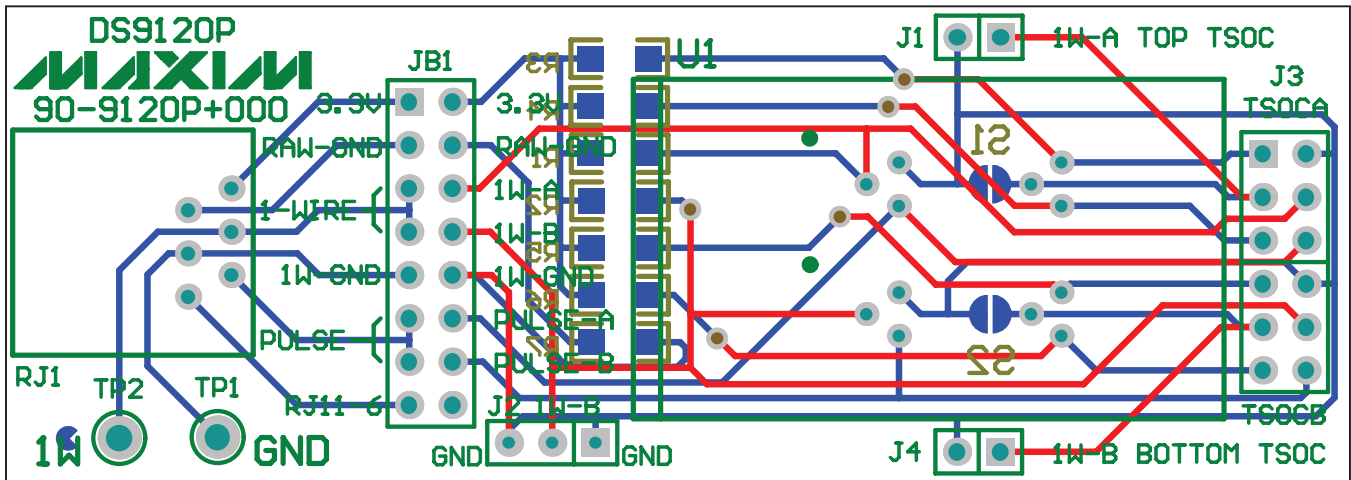

Figure 6. DS9120P+ Socket Board Composite Layout

DS9120 Socket Boards for Evaluating 1-Wire Devices

DS9120 Family of Socket Board Schematics and Layout (continued)

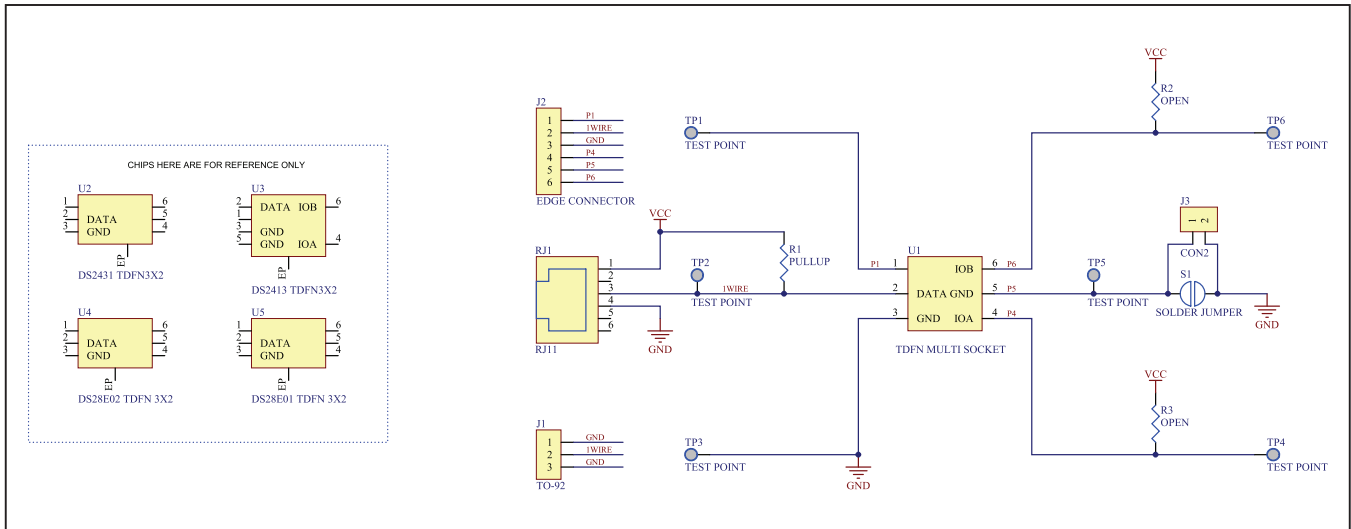

Figure 7. DS9120Q+ Socket Board Schematic

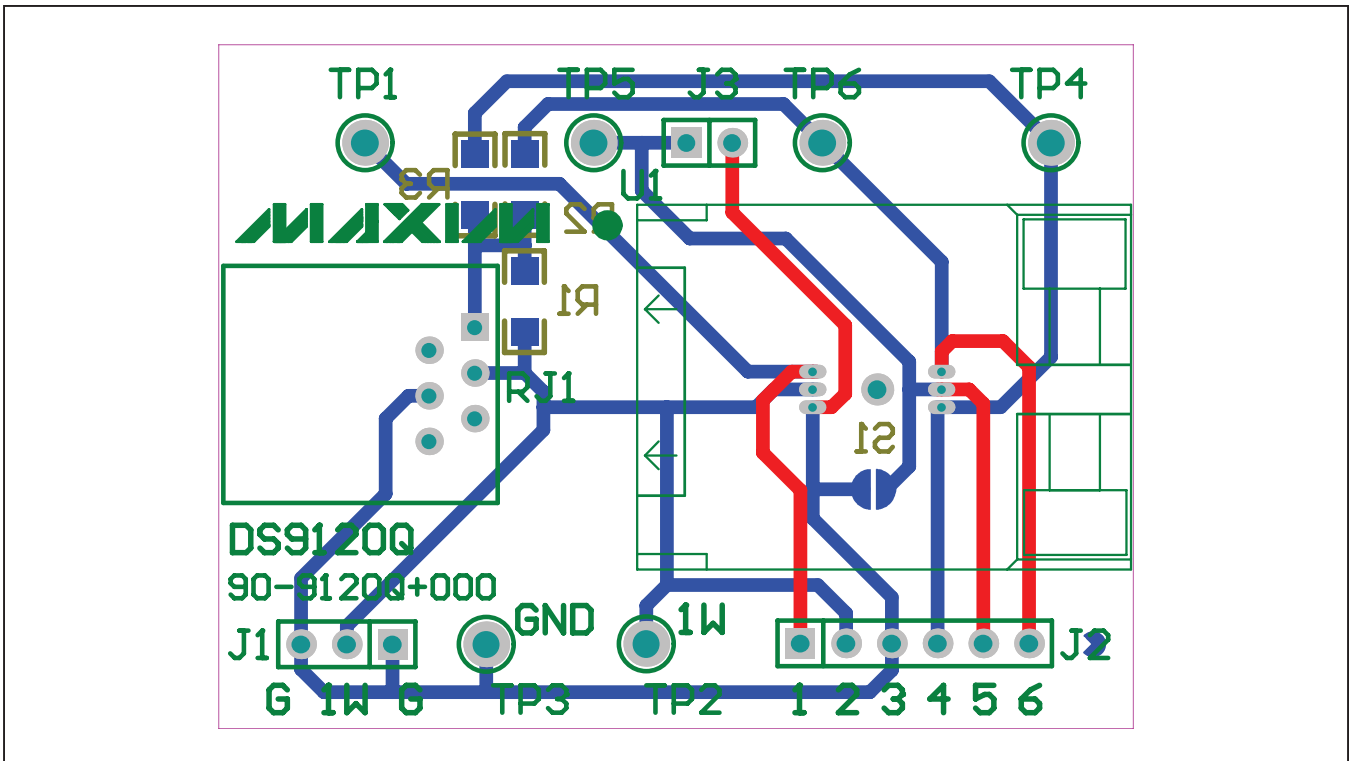

Figure 8. DS9120Q+ Socket Board Composite Layout

DS9120 Socket Boards for Evaluating 1-Wire Devices

Ordering Information

PART	TYPE
DS9120+	TO-92 Socket Board
DS9120P+	TSOC, TO-92 Socket Board
DS9120Q+	TDFN, TO-92 Socket Board
Contact factory for availability.	SFN, TO-92 Socket Board

Note: To use the DS9120 socket boards with the DS9481R USB-to-1-Wire adapter, order the DS9481R-3C7+.
+Denotes lead(Pb)-free and RoHS compliant.

DS9120 Socket Boards for Evaluating 1-Wire Devices

Revision History

REVISION NUMBER	REVISION DATE	DESCRIPTION	PAGES CHANGED
0	6/11	Initial release	—

Maxim cannot assume responsibility for use of any circuitry other than circuitry entirely embodied in a Maxim product. No circuit patent licenses are implied. Maxim reserves the right to change the circuitry and specifications without notice at any time.

Maxim Integrated Products, 120 San Gabriel Drive, Sunnyvale, CA 94086 408-737-7600 _____ 8